

ASSEMBLY INSTRUCTION

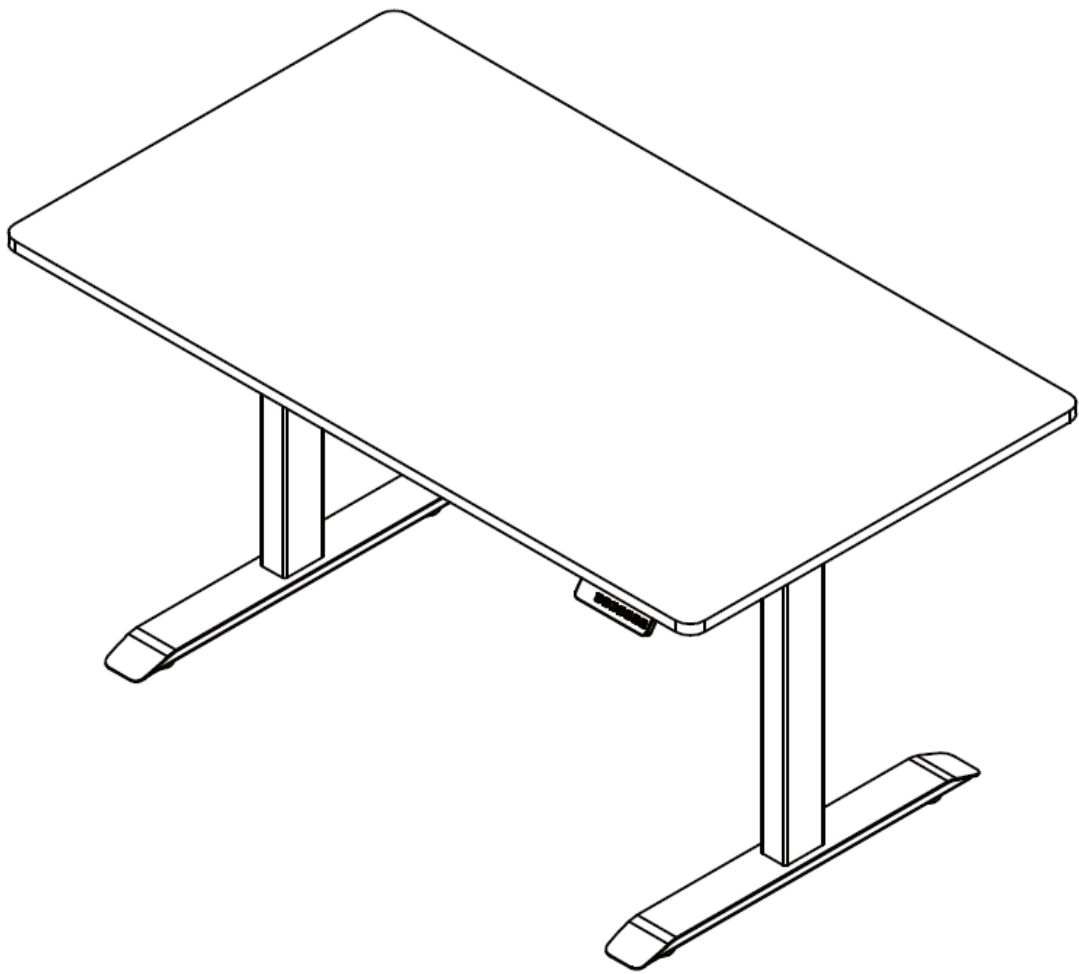

Make sure no obstacles are in the desk's path.
 Make sure the desktop is not touching any walls.
 Make sure all cords are appropriate length to accommodate the change in height.

WARNING
 Pinch Point! Keep hands and fingers clear.

- Keep all electrical components away from liquids.
- Do not sit or stand on the desk frame. Do not crawl or lie under the desk frame.
- Do not open any of the components - legs, control box, or switch.
- This product is designed with a duty cycle of 10%. (2 min. on, 18 min. off).

USE/LIABILITY

- This height adjustable desk has electric motors and is designed for use in dry work areas only.
- The desk height is adjustable so that it can be positioned at the most ergonomically suitable height.
- Any other use is at user's risk.
- Under no circumstances does the manufacturer accept warranty claims or liability claims for damage caused from improper use or handling of the desk frame.

PARTS

Required tools

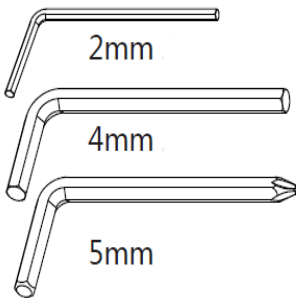

Components

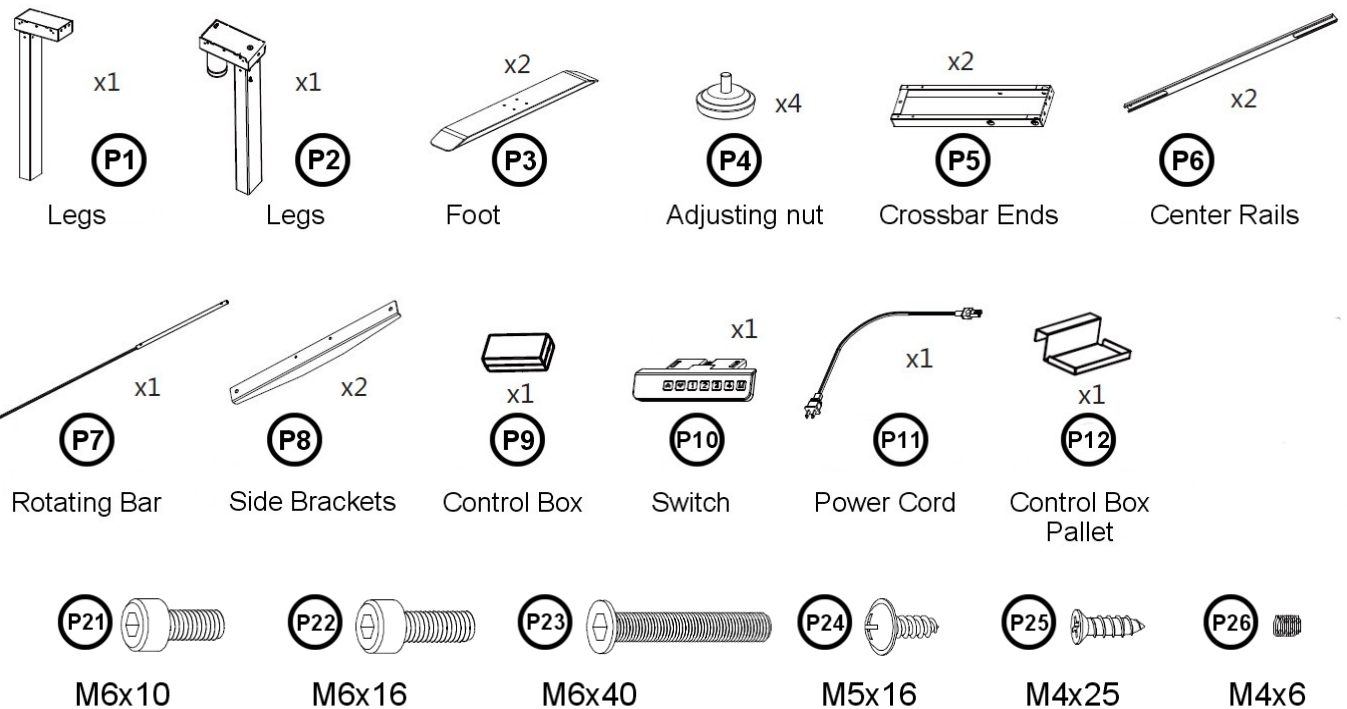

ASSEMBLY INSTRUCTION

REMEMBER: always use screws that are about 2-3 mm shorter than the tabletop thickness. In the tabletop use holes for screws with a diameter slightly smaller than the diameter of the screws.

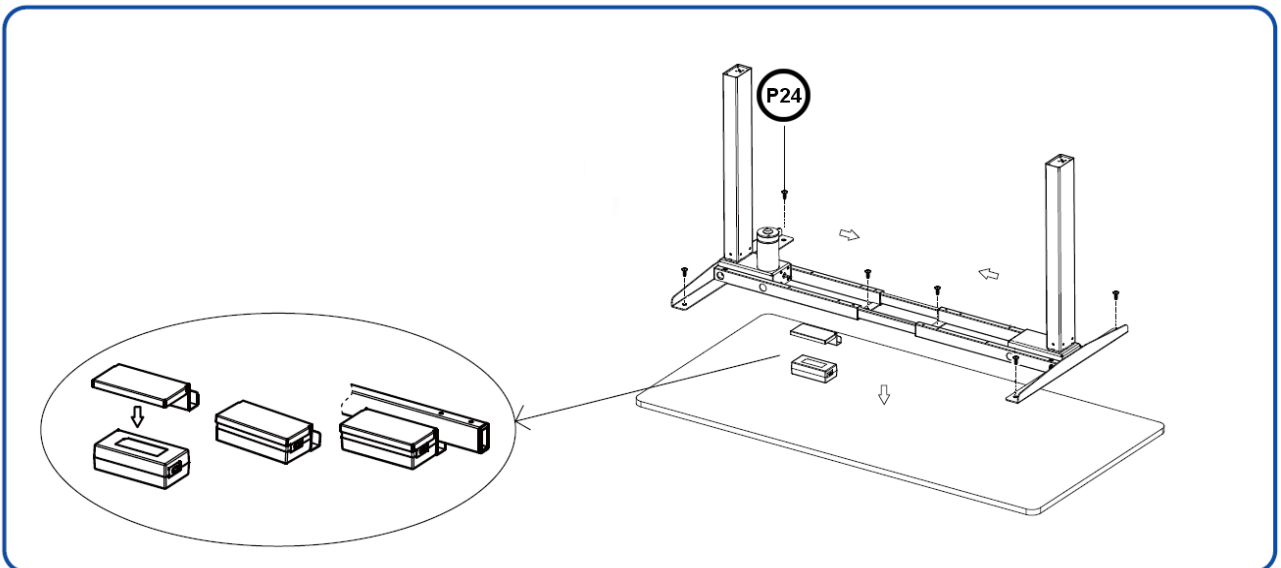
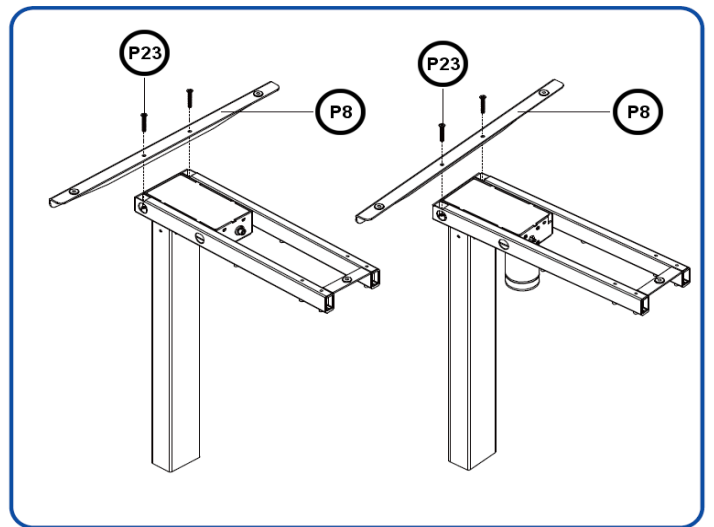
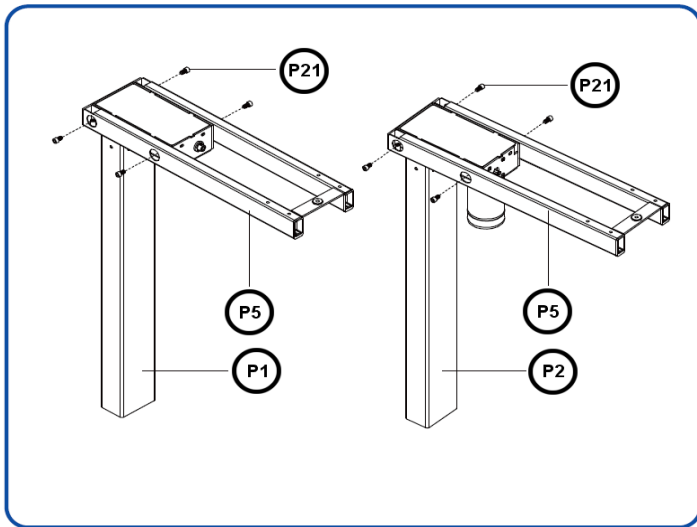
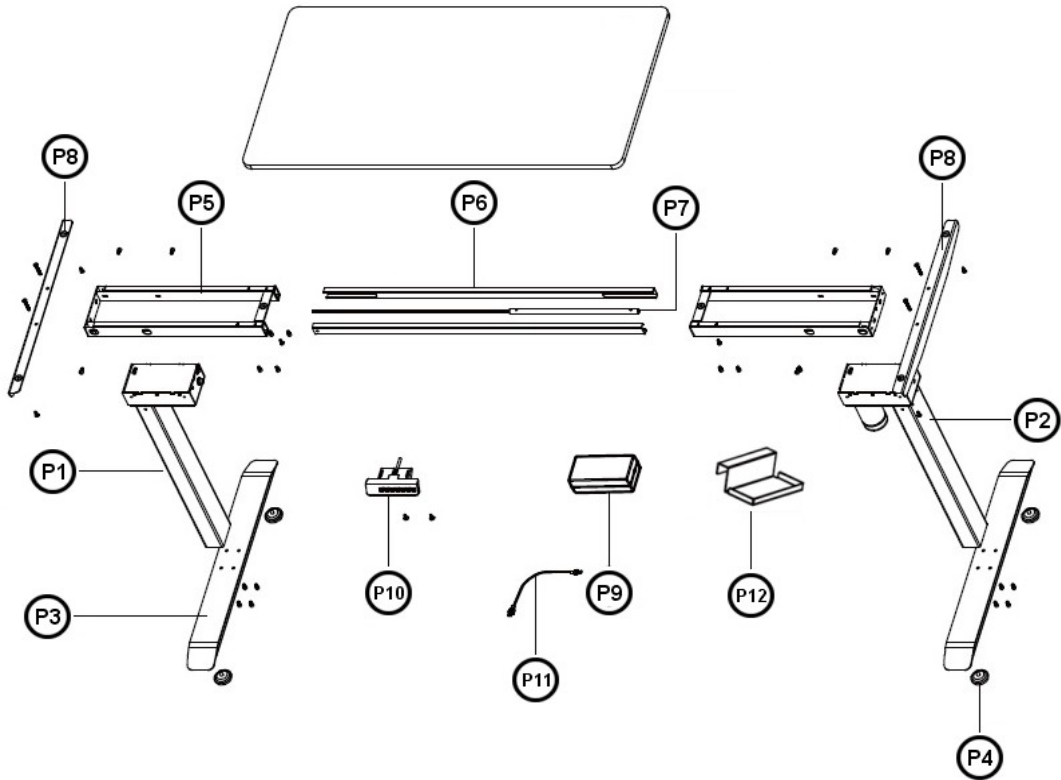

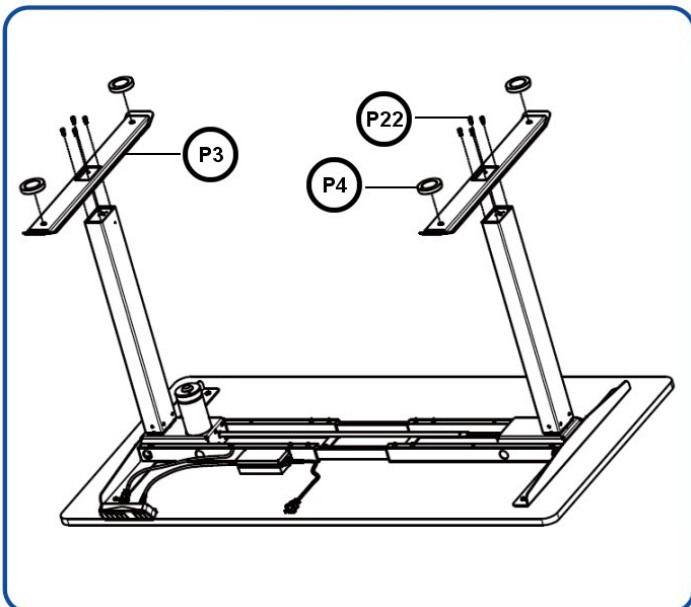
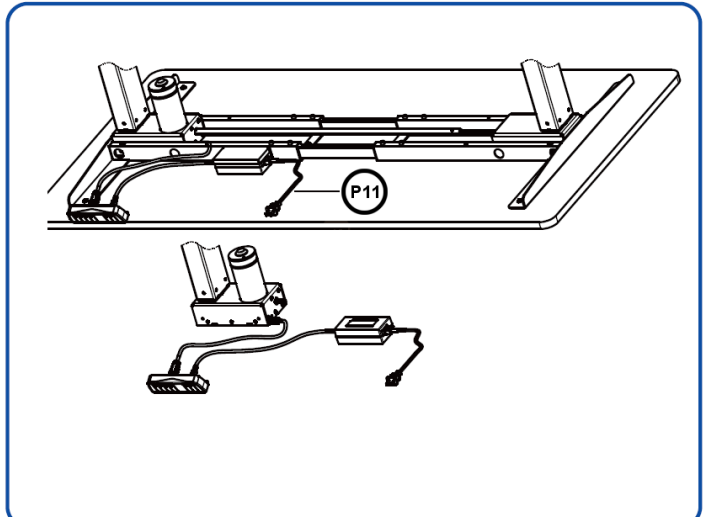
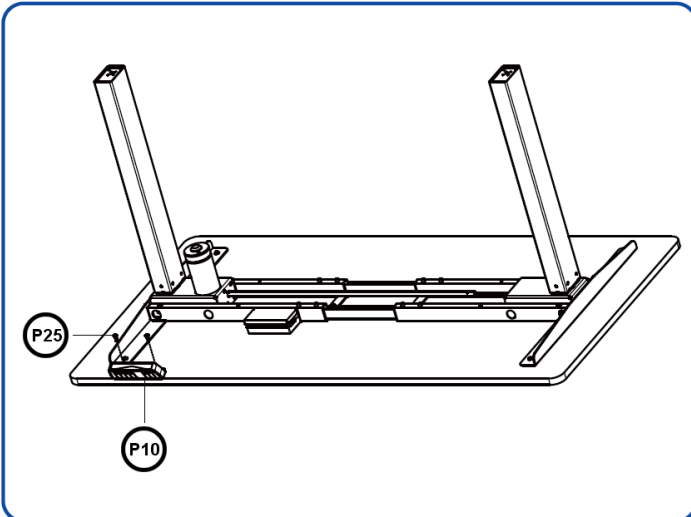
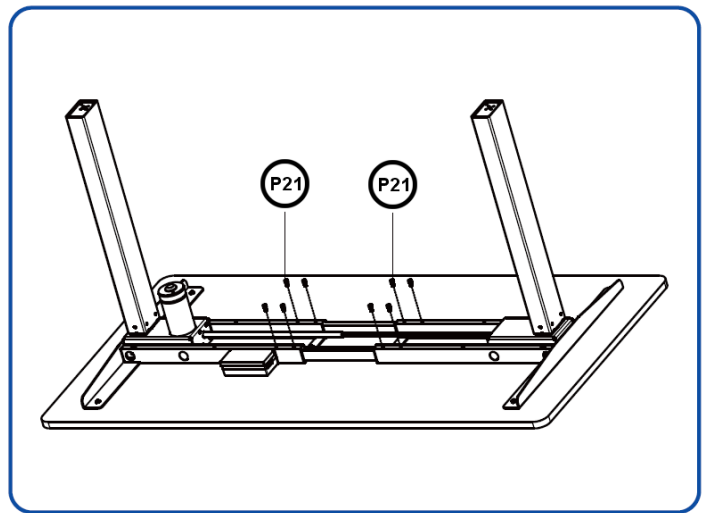
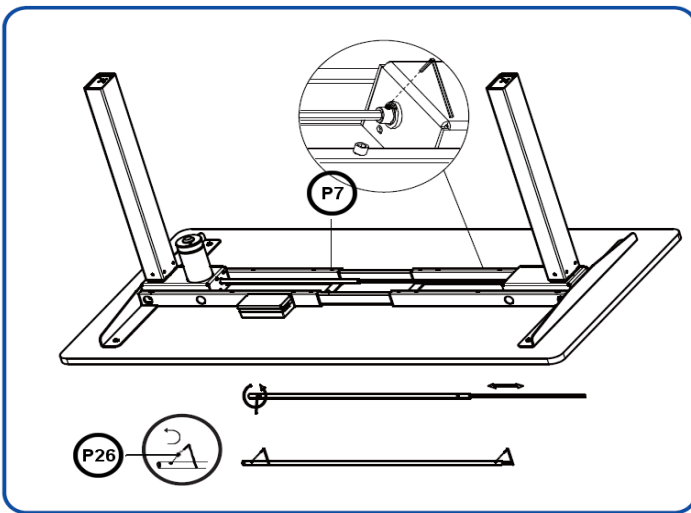

Plug the power cord into a 110 – 240 V outlet.

Make sure no obstacles are in the desk's path.
 Make sure the desktop is not touching any walls.
 Make sure all cords are appropriate length to accommodate the change in height.

Important: the desk must be reset prior to use.

Reset procedure: press and HOLD the DOWN BUTTON on the switch until the desk reaches its lowest height. Release the DOWN button. Press and hold the DOWN button again until the LED display „rES“. Release the DOWN button. Press nad hold the DOWN button again until the desk lowers a little bit more, slightly rises and stop. Release the DOWN button. Your desk is now ready to use.

If Your desk is not functioning properly it may need to be reset. Unplug the power cord for 20 seconds. Plug the power cord back in and follow the RESET procedure.